

**THE COMPLETE MOBILE WORKPLACE SOLUTION FOR  
PAINTWORK PREPARATION - THE PERFECT SOLUTION  
FOR COMMERCE AND INDUSTRY APPLICATIONS**

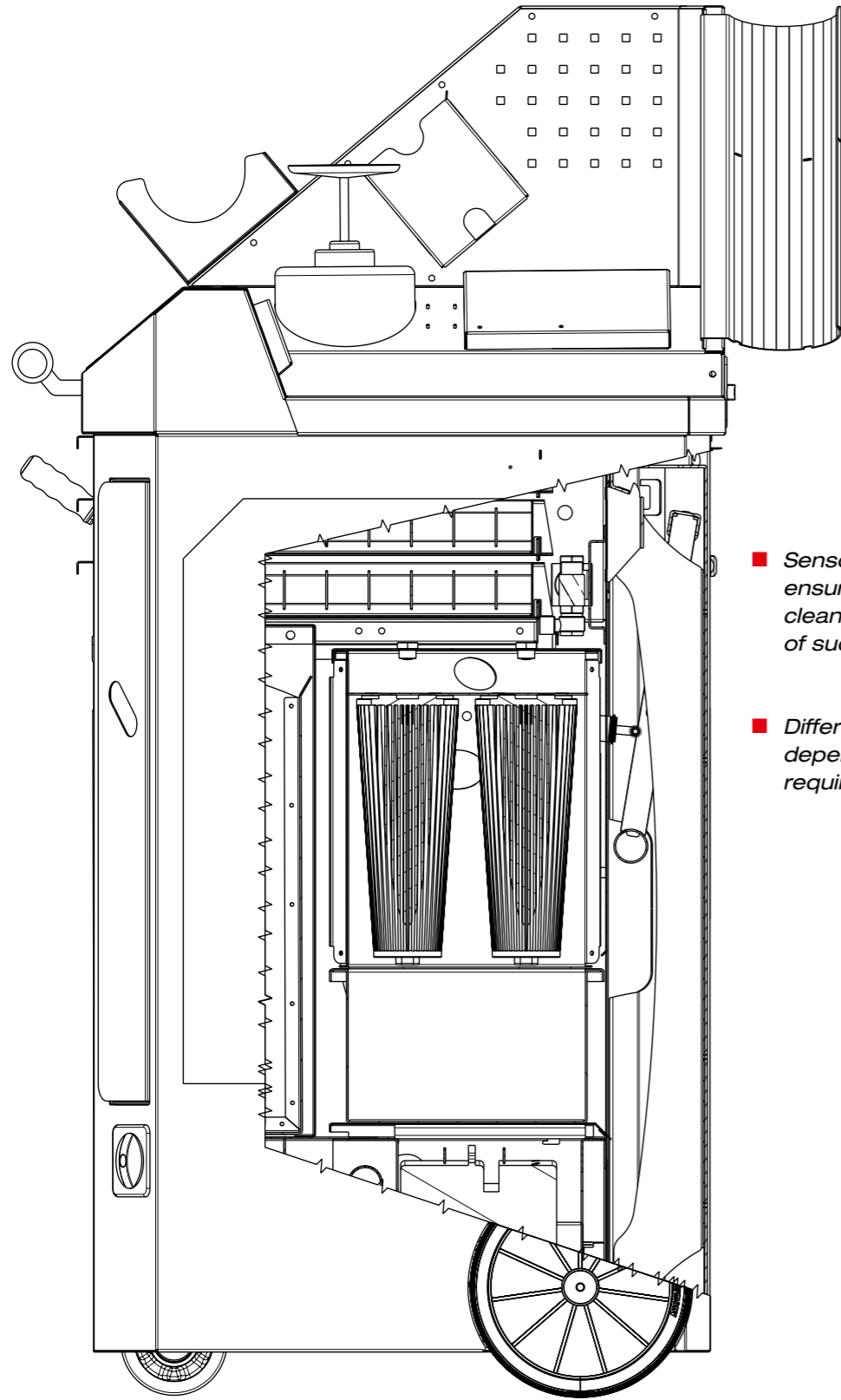

- *Sensor-controlled purgation ensures constant vacuum cleaning without interruption of suction power*
- *Different filter elements depending on the application requirements are available*

# **PWS EVOLUTION 2015**

**REDUCED TO THE MAXIMUM**







**THE REVOLUTIONARY DEVELOPMENT FOR PAINTWORK PREPARATIONS NO VACUUM CLEANER BAGS NEEDED - JET-SUCTION SYSTEM INCLUDED**



- Air pressure-coupling
- Locking mechanism Up and Down
- Holder for Hot Air Blower
- 2 Schuko-power-outlets 230V
- Foldable footboard „Up and Down“
- Air pressure gauge
- Air pressure coupling
- Power outlet 230V

- Holder for Excenter-grinding machine
- Speed Controller for Turbine
- Parking Brake
- Holder for flexible tube package
- Fuse box
- Double-jet-suction connector
- Air pressure coupling
- Schuko-power outlet 230V
- Luftaustritt für Turbine
- 2 Lenkrollen mit Zentralstop

- Perforated wall For flexible tool fixing
- Holder for cleaning Pads Immersion dispenser
- 7-slot grinding pad organizer
- Emergency off-switch
- Pressure regulator
- ED-light to indicate operation status

- 2 or 3 drawers, self-closing
- Smooth running Drawer, self closing
- Ruggedized Lock for Drawer



- Holder for adhesive tape
- Display gauge pressure regulation
- Washbasin for solvent
- Workspace made of stainless steel
- Vision panel made of safety glass
- Special reels for open mesh flooring



Removable 10 liter **Dustcontainer** for easy removal of dust



Easy access **Hatch** to clean filter of the turbine



**Up and Down** - integrated foldable footboard step ladder



**Parking Brake** - safely locks the steerable wheels



Integrated self-retracting **Cableroller** with 6 meters of industry grade power cable



Connection for **Air Pressure Supply**



Switch for **Double-Jet-Suction** connector